

The Clarity™ Margay is a 50" rear-projection display that offers wider aspect ratio and high brightness with zero-mullion rear-projection DLP* technology. It delivers high color performance and brightness in a tileable, high definition format that is ideal for creating large walls and digital signage.



FEATURES

Efficient form factor
50" display only 17.7" deep

Zero-mullion design
seamless multi-display configurations

High image quality
outstanding color performance
and brightness

Motorized image and cube control
remote control for fast set up

Easy serviceability
Full front and rear access
to components

Remote on-screen messaging
Message In Picture (MIP)

CLARITY MARGAY

Display resolution	1280 x 720 (720p)
Display technology	Single-chip DLP*
Aspect ratio (W:H)	16:9
Screen dimensions	
Diagonal	50" (127 cm)
Width by height	43.6" x 24.5" (110.7 cm x 62.2 cm)
Cabinet dimensions (WxHxD)	43.6" x 32.5" x 17.7" (110.7 cm x 82.6 cm x 45 cm)
Maximum tilt	15°
Maximum stack height	4 units (>6 units with tie back support)
Screen types	High-contrast acrylic
Viewing angle (1/5th gain)	+/- 45° (V/H)
Brightness	350 nits (120 fL)
Border (mullion)	<1mm
Brightness uniformity	> 80%
Contrast ratio (full field)	1,000:1
Weight*	68 lbs
Lamp type	120 watt UHP
Lamp life (median)	6,000 hours
Power consumption	~200 watts
Serviceability	Full front/Full rear
Rear clearance	Zero required
Colors	16.7 million
Color gamut	>70% NTSC, >100% EBU color
Operating temperature	32-104° F (0-40° C)
Operating humidity	20-80% non-condensing
Safety regulations	Complies with UL, cUL, FCC Class A, CISPR22/85, CE (Designed to meet EN60950)
Data input (standard)	VGA to UXGA (UXGA@60Hz)
Analog	2 x HD15 (supports 420p, 480p, 720p, 1080i HD formats and RGBHV) - with loop through
Digital	DVI-D - with loop through
Video Inputs (optional)	NTSC/PAL/SECAM Composite (1X RCA) with loop through Component (3 x RCA) with loop through S-Video on Mini DIN 4-pin connector with loop through
Ambient noise	36 dB
Cube control	RS-232, RS-485, WallNet and IR remote
WallNet™	Supported
MIP	Supported

*Weight and dimensions are approximate.



For more information

To learn more about the Clarity Margay by Planar Systems, call 503-748-1100 or visit www.planarcontrolroom.com or www.planardigitalsignage.com.

Makes a big impression

Margay is designed for multi-display towers, banners and walls used in both digital signage and video wall applications. The result is a seamless image area for presenting impactful graphic, photographic and video content in any environment – from retail stores to large control rooms.

Accessories and options

Margay Screen Brace (MSB-5040) – Designed to simplify and optimize screen alignment in wall applications. Required for each display in the bottom row of any wall configuration.

Big Picture™ (BP-5040) – Internal magnification capability to spread a single input over multiple displays.

WallNet™ – Enables diagnostic control and troubleshooting from remote location. One WallNet is required per wall.

Views

front

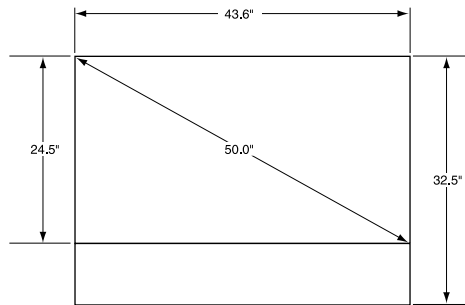

side

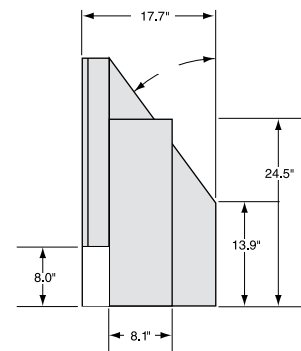

control panel

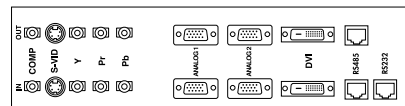

Planar Systems, Inc.
1195 NW Compton Drive
Beaverton, OR, 97006-1992, USA
Toll Free +1-866-475-2627
www.planar.com

Planar is a trademark of Planar Systems, Inc. All other trade and service marks are the property of their holders.

Copyright © 2008 Planar Systems, Inc. All rights reserved. This document may not be copied in any form without written permission from Planar Systems, Inc. Information in this document is subject to change without notice.